

CENTRIFUGE

Math-oriented

DATA:

Radius of primary axis (**R**) (measured from center of ride to center of car cluster): _____

Radius of secondary axis (**r**) (measured from center of car cluster to center of car): _____

Indicate on diagram the directions of rotation (as seen from above)

Period of rotation of the whole platform: _____

Period of rotation of car cluster: _____

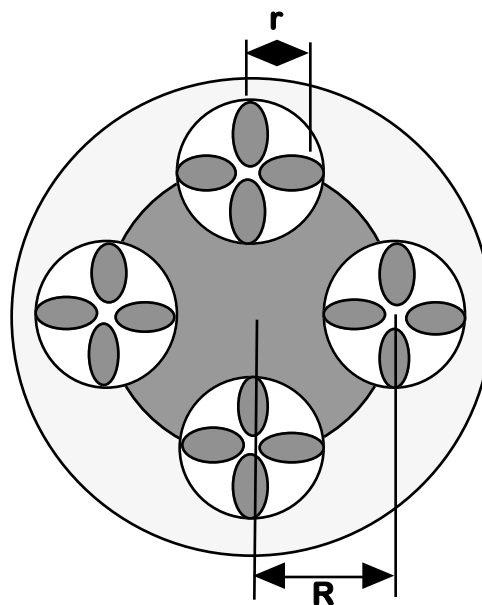

In the problems that follow, ignore the fact that the entire ride is set at an angle to the horizontal. Consider the ride as if it were running in a horizontal manner. Consider a passenger who is seated nearer the outside of the ride rather than closer to the inside.

PROBLEMS (to be answered on back or separate page)

1. Given the rotation speed and the radius of the car cluster, write an equation to describe the x-position vs. time for an individual car in the frame of reference of the car cluster. Write a second equation for the y-position vs. time for an individual car.
2. Given the rotation speed and the radius of the car cluster on the total ride platform, write an equation to describe the x-position vs. time for a cluster in the frame of reference of the stationary ground below the ride. Write a second equation for the y-position for a cluster.
3. Combine your two equations for the x-position and your two equations for the y-position to predict the overall position of an individual car relative to the stationary ground.
4. Sketch the graphs that are formed by these equations. (If possible, plot them on a graphing calculator, if you brought one, to check it out.)
5. Model the behavior of an individual rider by transferring your work to a spreadsheet and combining the x- and y-position equations to produce the overall motion of a rider. Does your final result agree with your observations and/or ride experience?

CENTRIFUGE

Math-oriented

DATA:

Radius of primary axis (**R**) (measured from center of ride to center of car cluster): _____

Radius of secondary axis (**r**) (measured from center of car cluster to center of car): _____

Indicate on diagram the directions of rotation (as seen from above)

Period of rotation of the whole platform: _____

Period of rotation of car cluster: _____

Maximum lateral acceleration (**a_L**): _____ g's (measured on the ride at full speed)

Minimum lateral acceleration (**a_L**): _____ g's (on ride at full speed)

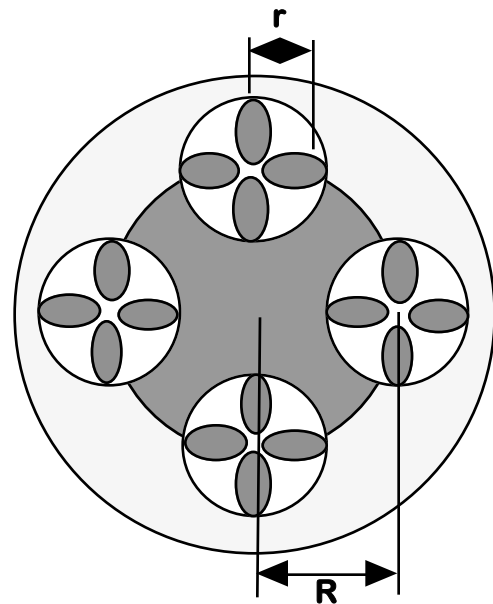

In the problems that follow, ignore the fact that the entire ride is set at an angle to the horizontal. Consider the ride as if it were running in a horizontal manner. Consider a passenger who is seated nearer the outside of the ride rather than closer to the inside.

PROBLEMS (to be answered on back or separate page)

1. Given the rotation speed and the radius of the car cluster, write an equation to describe the velocity vs. time for an individual car in the frame of reference of the car cluster.
2. Given the rotation speed and the radius of the car cluster on the total ride platform, write an equation to describe the velocity vs. time for a cluster in the frame of reference of the stationary ground below the ride.
3. Combine the results of your two equations to predict the overall motion of an individual car relative to the stationary ground.
4. Sketch the graph that is formed by this equation. (If possible, plot it on a graphing calculator, if you brought one, to check it out.)
5. Find the maximum and minimum accelerations (dv/dt) of an individual car as given by your equations.
6. Compare your measured accelerations with the calculated values.